

削らないから、「2秒で1本」「切りくずなし」「高強度」の
優れたねじ製造を実現。

This production method can achieve...
"Produce one screw per 2 sec." "No scrap" "High Strength"

SISねじ転造ヘッド

SIS Screw Rolling Head

SISねじ転造ヘッドで作られたねじは、
切削ねじや、研削ねじに比べ、
削らないから強度に優れ、短時間加工、
切りくず処理も不要な高い生産性を実現できます。

Screws made by rolling head excel cutting
screws or polishing screws in strength and
have extremely high productivity. For example,
they do not have problems with scrap disposal
because few scraps come out and can be
manufactured in a short time.

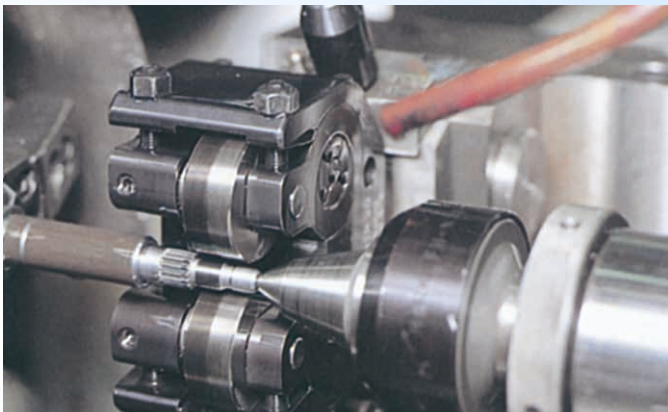

2~3秒で1本を生産。加工時間を大幅に削減

Product one screw per 2-3 sec.
Reduce the production time.

多種類のねじ加工ができる汎用性

Product various type of the screw

数万から数十万本の均一で高精度なねじ製造を実現

Available for the screw production of
high precision and uniform quality

あらゆる機械への取付けにも対応

Support for many varieties of the machine











株式会社 石金精機
Ishigane Seiki Co., Ltd.

SIS Screw Rolling Head

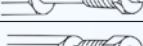
Cases of Rolling

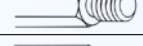
Cases of Screw Rolling by multi-axis automatic lathe and NC lathe

No.	Products form	Rolling screw form	Materials	Number of products rotations	Used model
1		M8×1	SUM21	2,200rpm	NTR16
2		M5×0.5	BsBM	3,500rpm	NTR16
3		PF3/4 PT1/2	SS400	600rpm	NTR28
4		M6	S45C	2,000rpm	NTR16
5		PT3/8	BsBM	1,780rpm	NTR20
6		3/4-16 UNF	BsBM	1,780rpm	NTR20
7		M13×1.5	SUM22	1,120rpm	NTR20
8		PT1/8	SUM21	2,000rpm	NTR20
9		M8×1	BsBM	2,200rpm	NTR16

Cases of Screw Rolling by single function machine

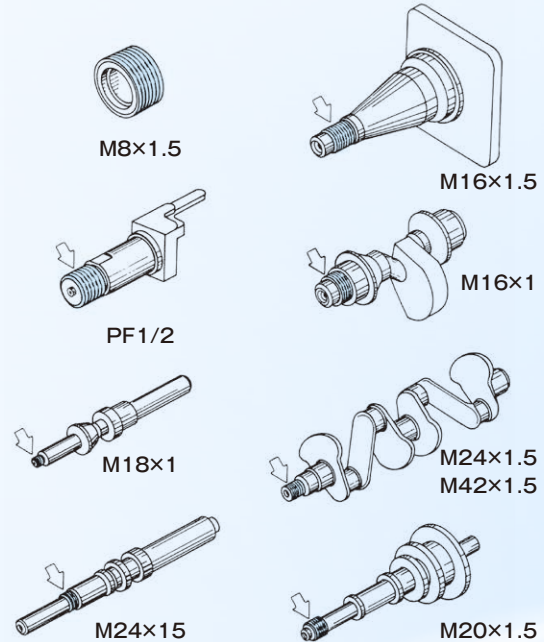

Products Line up

Standard Type, DRY & WET, Double-Axle

NTR 16VC 20VC NTR 28 36

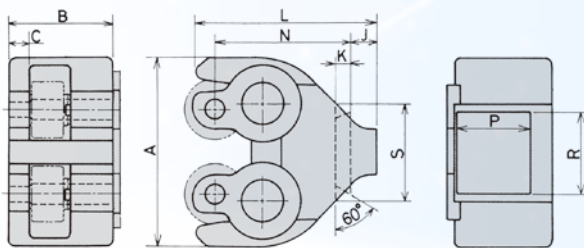

Size

Unit:mm

Type	Size-range of screws		A	B	C	J	K	L	N	P	F	S
	Diameter	Length										
NTR16	MAX16	MAX15.5	92	50	10	12	7	86	64.5	40	40	46
NTR20	20	21.5	122	65	13	15.5	7	107	79.8	50	50	60
NTR28	28	27	155	78	16	14.5	10	124.5	97	60	60	70
NTR36	36	27	210	88	20	16	13.5	147.5	115	67	70	76

Recommending to use one-lank-higher model when its screw pitch is wider than usual, and also when you process the part of maximum size of the work when the material is high-tension-steel.

Standard Type, DRY & WET, Single-Axle

OTR 20 28

